

Entire pamphlet Copyrighted by JACO Designs 1972 ©

This pamphlet contains the plans and instructions necessary to construct the Western pistol. This pistol breaks open to load and clean and is locked closed with a lever that is located at the front of the trigger guard. Empty cases are automatically extracted when the gun is opened. The hammer spring is a coil spring and is designed to produce extremely light sear forces in the full cock position. This arrangement makes the gun easy to cock. A separate firing pin allows the use of a simple flat faced hammer. There is a half cock notch for added safety.

The barrel may be made from an old rifle barrel or from a rifled blank commonly sold for replacing shot-out barrels. These can be obtained at gun supply houses. Should a rifled blank be chosen you can grind and file the blank or use a lathe to turn down and taper the barrel. The gun should be blued for a beautiful and rugged finish. JACO offers a hot bluing technique that is comparable in appearance and durability to those on factory made guns.

One sheet of the plans shows a sectioned side view, a top view, and a sectioned partial side view which shows the barrel open and the hammer cocked. The other sheet shows details and patterns used for construction of the various parts. These can be traced, cut and glued on the steel stock to assist in cutting out the parts.

Before starting to cut metal it would be wise to read all the instructions and learn as much as possible about the pistol. This design has been refined by building and testing earlier models. Intricate mechanisms requiring close fits have been eliminated without sacrificing important features. If you build the pistol as instructed you will have a completely satisfactory weapon. Because we have no control over the materials you use, the workmanship or possible use of the pistol, JACO will not assume any responsibility for the pistol.

Most of the stock required is Cold Rolled Steel (CRS) and can be obtained at any steel supply house. Other than common tools like screwdrivers and files, etc., the only tools needed are a hacksaw, drill press and bench vice. Additional tools such as a bandsaw and a lathe will make the work go easier and faster but are not essential.

You may be tempted to alter the design to suit your own preference like a longer barrel or a differently shaped handle. JACO encourages these innovations because they add to the satisfaction of building your own pistol. The builder, however, is cautioned against changing the interior mechanism without thorough study since this design has been proven.

These plans and instructions are not to be copied in whole or in part by anyone without written consent of JACO.

- 1 - MATERIAL - All the material for this pistol is soft cold rolled steel stock except for the springs which must be music wire. You will need a 1/8 x 5 x 5 inch plate and a 5/16 x 4 x 6 inch plate, and rods 3/16 dia. x 3 inches long, 1/8 dia. x 3 inches long and 3/32 dia. x 3 inches long. You will also need some music wire, .025 diameter about 4 inches long and some .045 diameter wire about 36 inches long. In addition, several .062 dia. (16 gauge) nails will be needed for various pins.
- 2 - PATTERNS - Do not cut up your plans. Trace the outlines of the various parts and make paper patterns that you can glue on the steel sheets. You can saw outside the patterns and easily rough out the parts. If you prefer, color the steel with red "Magic Marker" and scribe the outlines of the parts on the steel. Plan ahead when laying out the parts so you can easily saw out the parts.
- 3 - SAW OUT PARTS - Saw out all the parts leaving a little stock for clean up with a file. Drill holes at the locations shown to give the inside radii as necessary. Do not put in sear notches in the hammer. The Side Plates (28) & (31) should be clamped and filed together. Critical dimensions such as at the trigger sear, hammer sear notches, latch face and extractor should be left oversize and finished at assembly.
- 4 - ASSEMBLE ON ONE SIDE PLATE (PARTIAL ASSEMBLY) - Mark the location of the three rivet holes in the Trigger Guard (22), two rivet holes in the Handle (13) and center punch. Drill each hole through with 1/16 inch drill. Mark the location of the two pin holes in the breech block, part 8, and drill through with a 3/16 inch drill. Locate the trigger guard on the right side plate in indicated position, clamp together and drill the three holes through with a 1/16 inch drill. Pin with 1/16 inch dia. (16 gauge nail) pins, 1/16 inch long. Butt the handle against the trigger guard, clamp and drill through both holes with 1/16 inch drill. Pin with 1/16 inch dia. pins 5/8 inch long. Locate Breech Block (part 8) on right side plate, part 28, as indicated, clamp and drill the two holes through with a 3/16 inch drill. Insert two 3/16 inch dia. CRS pins (11) (12) 5/8 inch long to hold the breech block and side plate together.

- 5 - HAMMER - Locate, center punch and drill hole for Hammer Pin (17) with a 1/8 dia. drill. Locate Hammer (10) in its proper position on side plate in the partial assembly. The face of the hammer should be flat against the breech block. Clamp and drill through with 1/8 inch drill. Pin with 1/8 inch dia. CRS pin 5/8 inch long.
- 6 - TRIGGER - Locate, center punch and drill the hole for Trigger Pin (18) with a 1/8 dia. drill. Locate Trigger (20) in its indicated location on the side plate in the partial assembly. The trigger sear and hammer sear notch must have sufficient stock so that they can be filed to fit together. Clamp and drill through with 1/8 inch drill. Pin with 1/8 inch dia. CRS pin 5/8 inch long.
- 7 - TRIGGER AND HAMMER OPERATION - Place hammer in the full cock position as indicated. File trigger sear and hammer sear notch so that they engage at this point with an overlap of about 0.020 inch. Place hammer in the half cock position (about 1/8 inch off of breech block) and file half cock notch so that it engages trigger sear at this point with an overlap of about 0.030 inch. The half cock notch must be recessed somewhat in the hammer so that the hammer does not catch in this notch when falling from the full cock notch.
- 8 - FRAME ASSEMBLY - Place left side plate on top of partial assembly and clamp in the correct position. Remove one pin at a time and drill through each hole replacing the pin through the entire assembly before starting the next hole. Mark and disassemble frame. Drill the external side of each rivet hole (five total) in the side frames with a 5/64 drill to a depth of 1/16 inch. Reassemble frame and trim the rivets to stick out 1/16 inch. Crush each rivet one at a time between the smooth jaws of a bench vise.
- 9 - BARREL - Obtain Barrel (3) from an old .22 Caliber rifle, 6 inches long or purchase a rifled blank from a gun supply house. If an old rifle barrel is used, the barrel will be tapered and the correct diameter and no lathe work is required. If a rifled blank is purchased, the barrel should be ground or turned down to a diameter of 11/16 inches. The muzzle end of the barrel is tapered starting at the middle of the barrel length to a dia. of 5/8 inch at the muzzle. Crown muzzle end of barrel and square breech end of barrel. Draw file a flat on barrel 5/16 inch wide by 2-1/2 inches long to fit part 26. Layout extractor, part 9, notch and file out as indicated.
- 10 - BARREL BLOCK - Layout and file extractor tang on Barrel Block, part 26, 3/16 inch thick as indicated. Lay out, center punch and drill screw clearance holes through as indicated with 13/64 inch drill. Counterbore the indicated hole with a flat bottom, 1/4 inch drill to the depth of 1/16 inch. Lay out the extractor slot and center punch the center of 1/8 inch dia. that will serve as the ends of the slot. Drill through with 1/8 inch drill. Remove the metal. In the slot between the holes by drilling as many 1/8 inch diameter holes as possible. Finish slot by filing. Layout, center punch and drill latch pin, part 21, hole through with a 1/8 dia. drill.
- 11 - ASSEMBLE BARREL AND BARREL BLOCK - Clamp Barrel Block, part 26, on to the Barrel, part 3, in the indicated position and mark location of threaded holes by drilling a center point in the barrel with a 13/64 dia. drill. Remove barrel block and drill hole with No. 25 drill to a depth of 1/8 inch. Use a flat-bottom No. 25 drill and remove drill point from the bottom of holes. Tap holes with a No. 10 24 tap. Complete with bottoming tap to obtain maximum thread depth. Obtain two No. 10 - 24 round head steel screws, part 5 and 25, at any hardware store, 3/4 inch long. Cut each to the length's indicated. Chuck into the drill press and file heads to 15/64 inch in dia. Position barrel block on barrel and assemble with screws.
- 12 - ASSEMBLE BARREL ASSEMBLY AND FRAME - Chamfer inside edges of side plates where they will contact barrel. Slide barrel assembly into frame back against the breech block and down on the side plates and clamp. Locate, center punch and drill hinge pin hole through with 3/16 dia. drill. Make Hinge Pin, part 27, from a 3/16 dia. rod 5/8 inch long and insert.
- 13 - LATCH - Lay out, center punch and drill a 1/8 dia. drill through Latch, part 23. Assemble latch into barrel block using a 1/8 inch dia. Latch Pin, part 4, 5/16 inch long. File latch step so that it engages trigger guard to hold the gun securely closed. File where required to fit latch slot in trigger guard. Drill latch as indicated with 1/32 inch drill for Latch Spring, part 24. Make latch spring from 0.025 inch dia. music wire about 1 inch long. Insert in latch, stake and bend to indicated shape.
- 14 - EXTRACTOR - Lay out and file notch in Extractor, part 9, as indicated. The width of the notch should be made to fit the tang on the barrel block. The extractor should be made to fit the barrel as perfectly as possible in the chamber area. Excess extractor material should be removed so that it does not extend beyond the breech of the barrel except for the extractor lug. Lay out, center punch and drill extractor pin hole through with a 1/8 dia. drill. Locate extractor on barrel assembly, clamp and drill through tang with 1/8 inch drill. Pin with 1/8 dia. Extractor Pin, part 21, 5/16 inch long.
- 15 - CHAMBER THE BARREL - Use a No. 2 drill and drill the breech end of the barrel with extractor in position 0.77 inch deep. Open hole with a No. 1 drill to the same depth. Drill to a depth of 0.040 inch with a 9/32 dia. drill.

16 - FIRING PIN - Mark the center of the barrel on the breech block. Marking is best accomplished by using red "Magic Marker" on the face to be marked and using a pointed brass rod 1/16 inch in diameter to reach through the barrel. Tap out breech block pins and remove the breech block from the frame. Measure up from the center 3/32 inch, center punch and drill the firing pin hole through with a 1/8 dia. drill. Make Firing Pin, part 6, from a 1/8 dia. rod as indicated. The point can be produced by chucking the firing pin in a drill press and shaping with a file. File the retaining flat as indicated. Reassemble the breech block into the frame. Locate, center punch and drill retaining pin hole with a 3/32 dia. drill, through the assembly. Assemble firing pin in position and insert Retaining Pin, part 7.

 Lay out and file rear sight 1/6 inch wide 1/16 inch deep centered over the bore.

17 - HAMMER SPRING - Wind Hammer Spring, part 14, using 25 coils of 0.045 inch dia. music wire on a slotted mandrel 0.192 inch in dia. Select a nail of this approximate diameter and slot one end with hacksaw. Wind the coils tightly together adding a few more coils to allow for some spring back. Trim and file the ends square. Using pliers, stretch and then compress the spring back to solid height. The resulting free length will provide approximately the correct spring preload when assembled. Slip hammer spring over Hammer Spring Guide, part 15, and assemble into handle as indicated.

18 - TRIGGER SPRING - Trigger Spring, part 19, is made from 0.025 inch dia. music wire 3/4 inch long. Disassemble trigger and drill a hole in the trigger as indicated with a 1/32 inch drill. Insert the trigger spring and stake in location by center punching around the hole. Bend spring as shown and re-install trigger.

19 - FRONT SIGHT - Front Sight, part 1, is made from 1/8 inch stock shaped as indicated; Drill a 1/16 inch dia. hole through front sight as shown. Carefully locate front sight on barrel in position shown. Be sure that the sight is centered over the bore. Mark the hole location on the barrel. Center punch and drill hole 1/8 inch deep. Use epoxy and assemble front sight and 1/16 inch Front Sight Pin, part 2, to barrel.

20 - WOOD HANDLES - Wood Handles, part 29 and 30, are best made from walnut wood. Handles are fitted to the gun and then shaped. It is important that the wood fits the vee notch in the side plates. Drill handle for locating pin, part 32 using a 1/16 dia. drill. Insert a 1/16 inch dia. CRS pin 7/16 inch long so that 1/16 inch protrudes from each side of the handle. Mark location of location pin on wood handles by pressing them down carefully. Drill handles 1/16 inch deep with 1/16 inch drill at marked location.

 Install wood handles using a Ho. 7 flat head wood screw, 1 inch long modified as indicated in detail, part 16. The screw should be inserted from the right side of the gun. The right handle should be drilled in the indicated location with 5/32 inch drill through. Counterbore hole with 9/32 inch drill to a depth of 1/8 inch. Insert screw and tighten by screwing into the opposite handle.

 Shape handles as indicated to obtain good fair-in between wood and metal parts of the handle. Wood handles should be finished with two coats of clear varnish with a light sanding between coats.

21 - STAMP - Using 1/16 inch stamps, letters and numbers, stamp your name, city and state and ".22 CAL." as indicated.

22 - FINISH - Finish file the gun with a smooth file all over first with the gun assembled to establish the proper "blend-in" of surfaces, then disassemble to reach all interior surfaces. Remove all external surface scratches and scuff marks that would mar the appearance of the finished gun. In finishing, it should be remembered that a gun traditionally has square corners that are broken slightly to eliminate sharpness. Excessive rounding of edges is not accepted gun practice. Wire brushing after smooth filing makes a good serviceable surface for a blued gun, intended for use in the field.

23 - TEST FIRE - Clean the gun thoroughly with solvent and oil gun mechanism with gun oil. Check gun for correct operation of latch, extractor, hammer, firing pin and trigger. Chamber a live round, cock hammer, sight target and squeeze trigger. Should the gun not fire, the firing pin is probably not striking the case with sufficient force, or not in the correct location or with too large a mark. Compare your mark with that made from a factory made gun, then make alterations and try again until successful.

24 - SIGHT IN - Set up target and fire a five shot group. If the gun shoots to the left, remove stock from the right side of the front sight. If the gun shoots low, remove stock from the top of the front sight. If the gun shoots high, remove stock from the top of the rear sight. The final thickness of the front sight should not be less than 1/16 inch.

25 - BLUEING - The gun should be cleaned of grease by washing all steel parts with lacquer thinner. The gun can be blued with any of the commercial cold bluing products but these tend to produce a superficial coating that is not very durable. JACO has developed a hot bluing solution that can be accomplished on the kitchen stove and provides as good a blue that is obtained commercially. See JACO brochure for ordering instructions.

26 - BOX - Select a good piece of White Pine 1 x 6 x 22 inches long. Cut board in half to form box and lid. Draw outline of gun on the box and the opposite outline on the lid. Remove wood by chiselling so that half the gun is recessed into the box and half in the lid. Sand and varnish box all over with clear varnish. Select felt material of desired color and glue down inside box. Complete with installation of miniature brass hinges and catch.

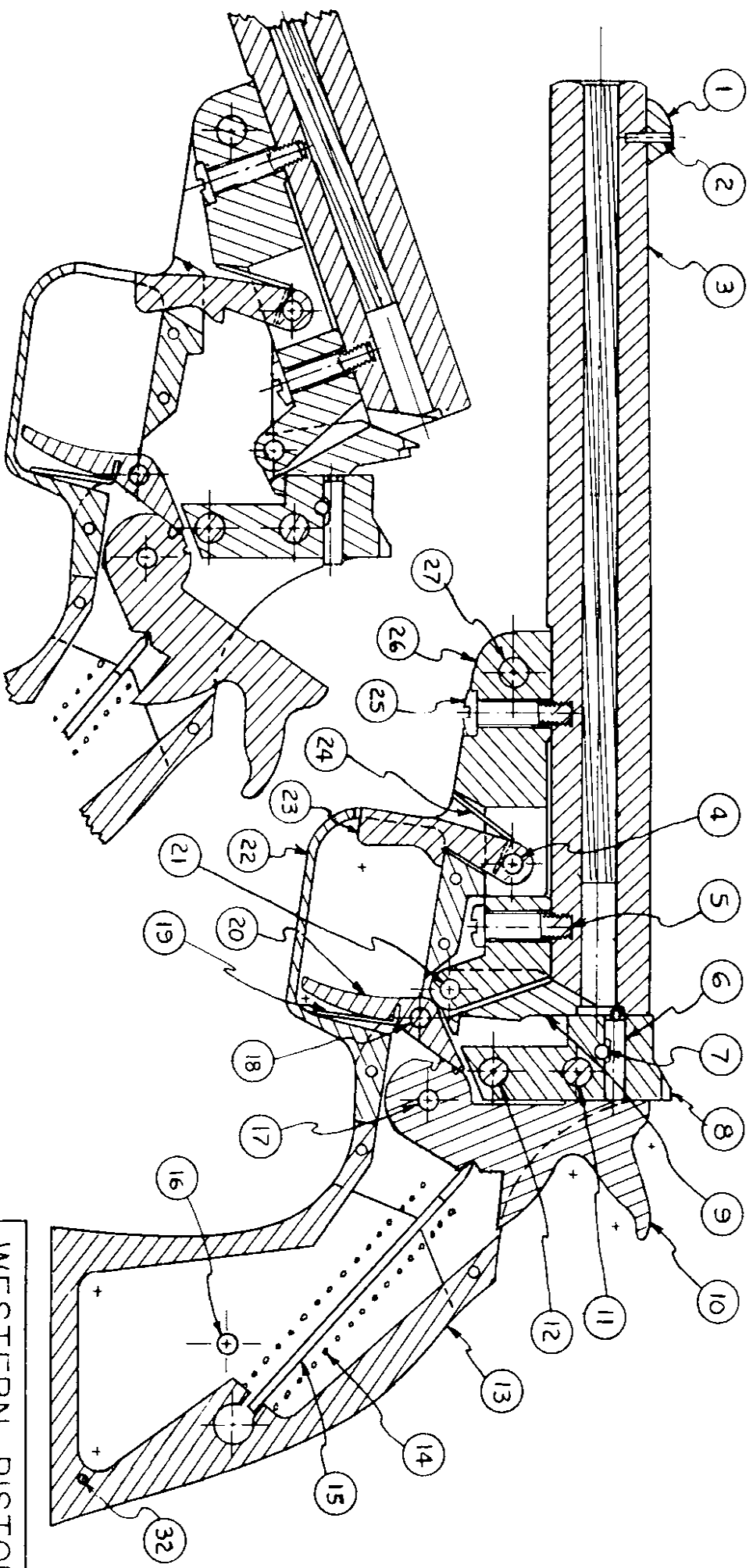
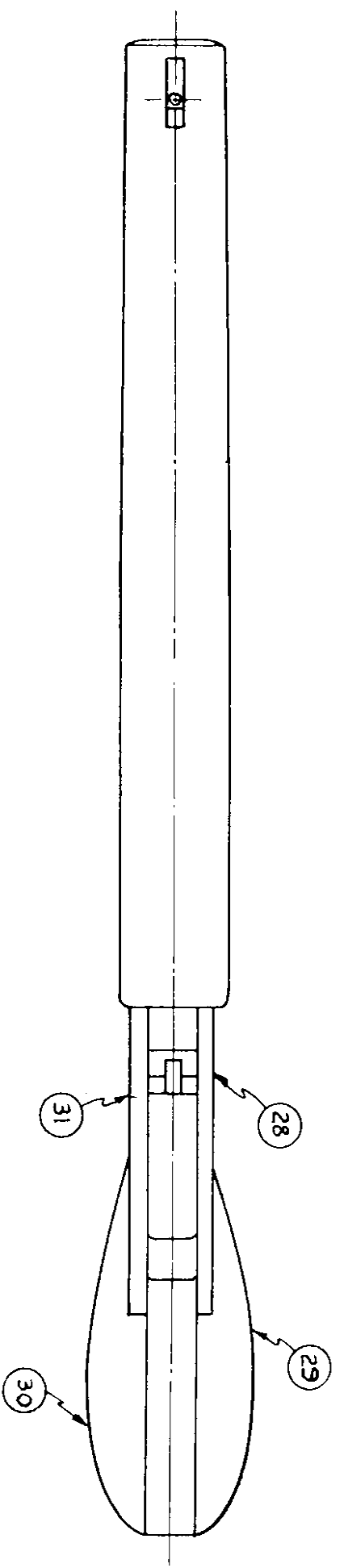

WESTERN PISTOL
 .22 CAL. SINGLE SHOT

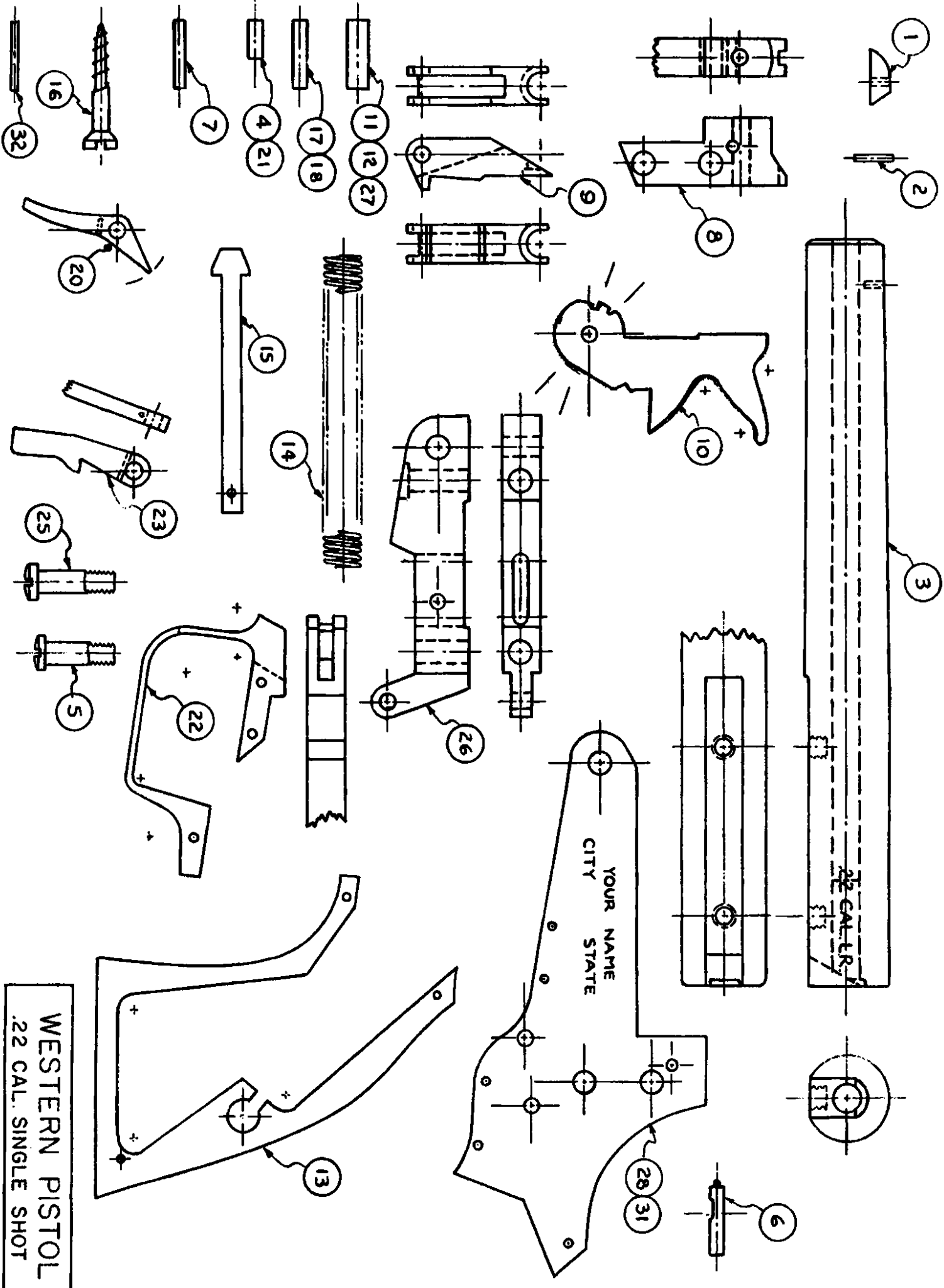

WESTERN PISTOL
 .22 CAL. SINGLE SHOT

